

LEVEL GAUGES FOR SOLID MATERIALS

- Flour
- Fertilizer
- Feeds
- Granulated materials
- Powdered materials

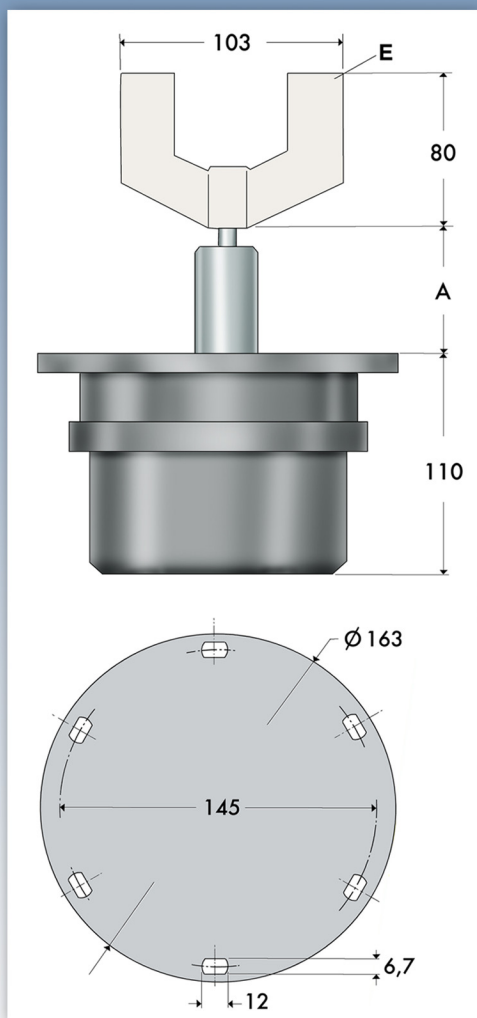

Execution: n° 5 different models of different lengths, with straightened rod A and propeller E of mm. 50

Tipo	A mm
1	90
2	190
3	315
4	500
5	1000

Characteristics:

- Flange and cover made of natural cottonite
- Power of geared motor 5 Watt
- Protection IP 55
- Maximum temperature of operation 80°C
- Microswitch A-5 V230 CA

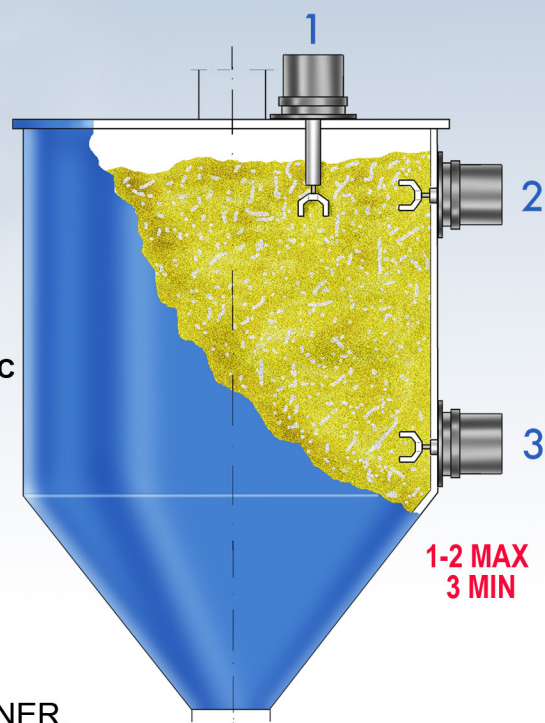
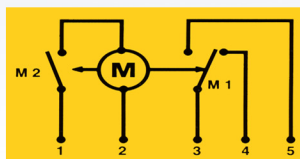

Working

- The equipment can be installed on every kind of SILOS or CONTAINER.
- If the container is empty, the propeller keeps on moving by means of a synchronous motor, fitted and free on the shaft.
- The propeller stops when solid material jams it; meanwhile the motor rotate till to switch the micro switch M1, keeps on the rotation till to open a second micro switch M2 removing tension to the motor.
- The propeller starts moving when the level of material goes down till to make the propeller free. In this moment the micro switch gives tension to the motor.
- The covering is completely airtight and can guarantee the working even in an open environment.
- Kind of tension: 230V, 110V, 24V 50hz.... (we can supply other tensions on demand).